

1 2 3 4 5 6 7 8 9 10 11 12

A  
B  
C  
D  
E  
F  
G  
H

A  
B  
C  
D  
E  
F  
G  
H

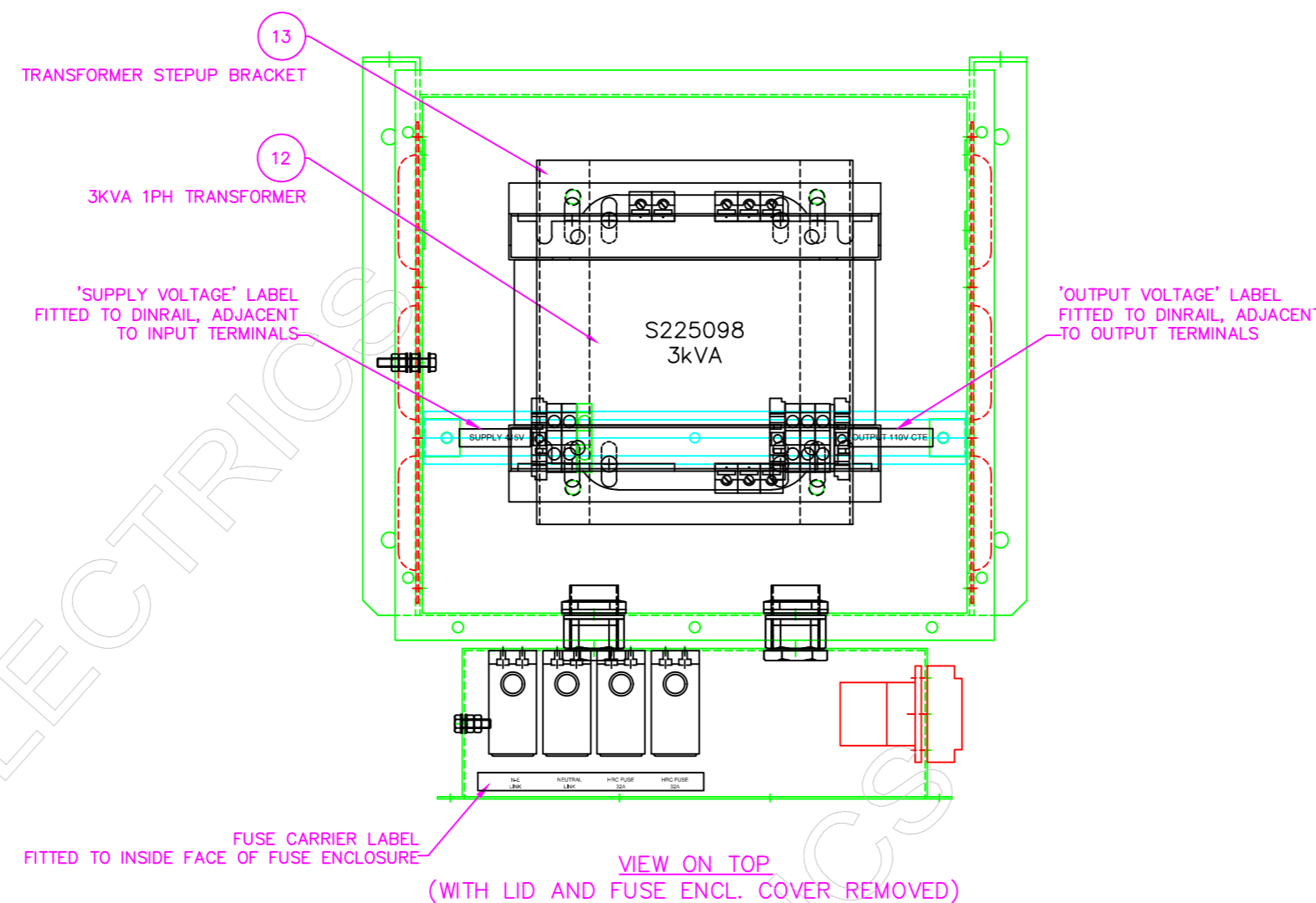

NOTES:  
 1. DRAWING SHOWS MAIN ASSEMBLY DETAILS.  
 2. REFER TO SHEET 1 'ITEM LIST TABLE', FOR DETAILS OF ITEMS SHOWN WITH NUMBER BALLOONS.  
 3. REFER TO SHEET 1 FOR EXTERIOR DETAILS AND ADDITIONAL INFORMATION.

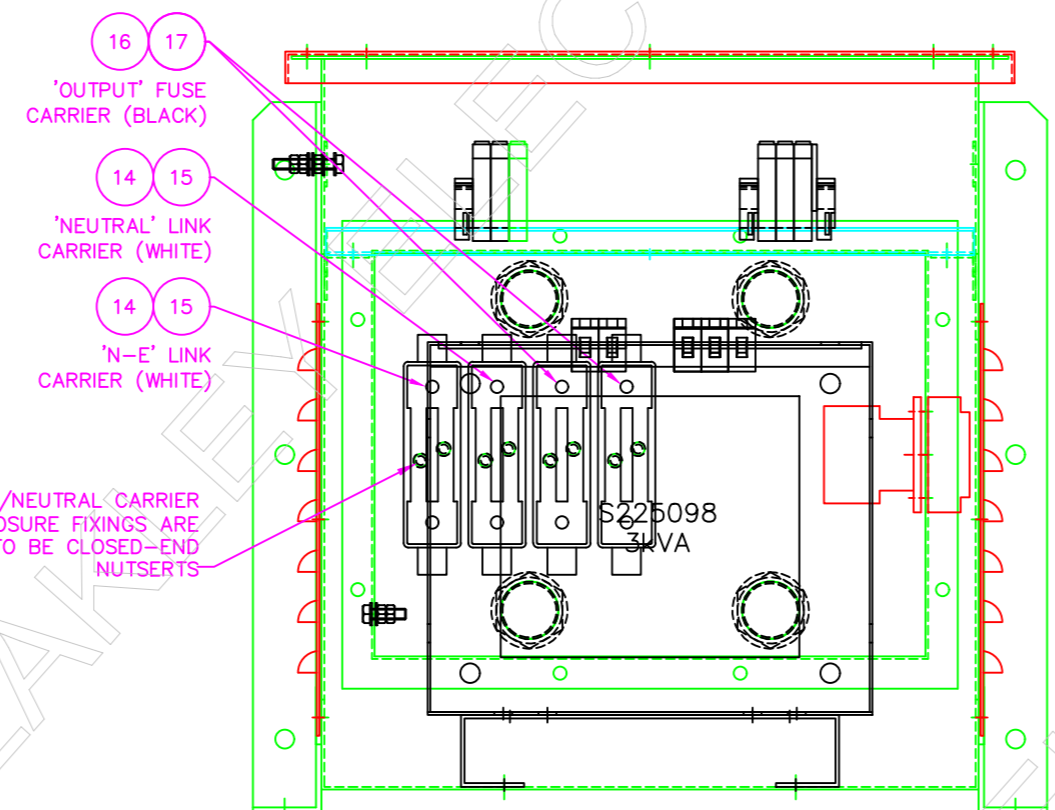
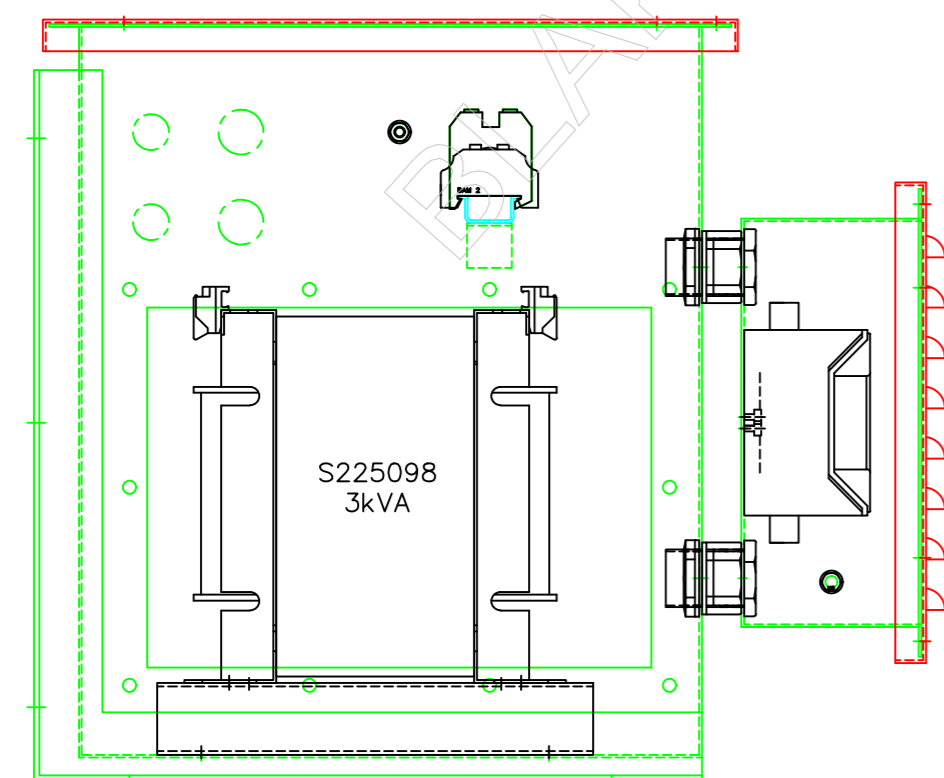

CUSTOMER INFORMATION COPY

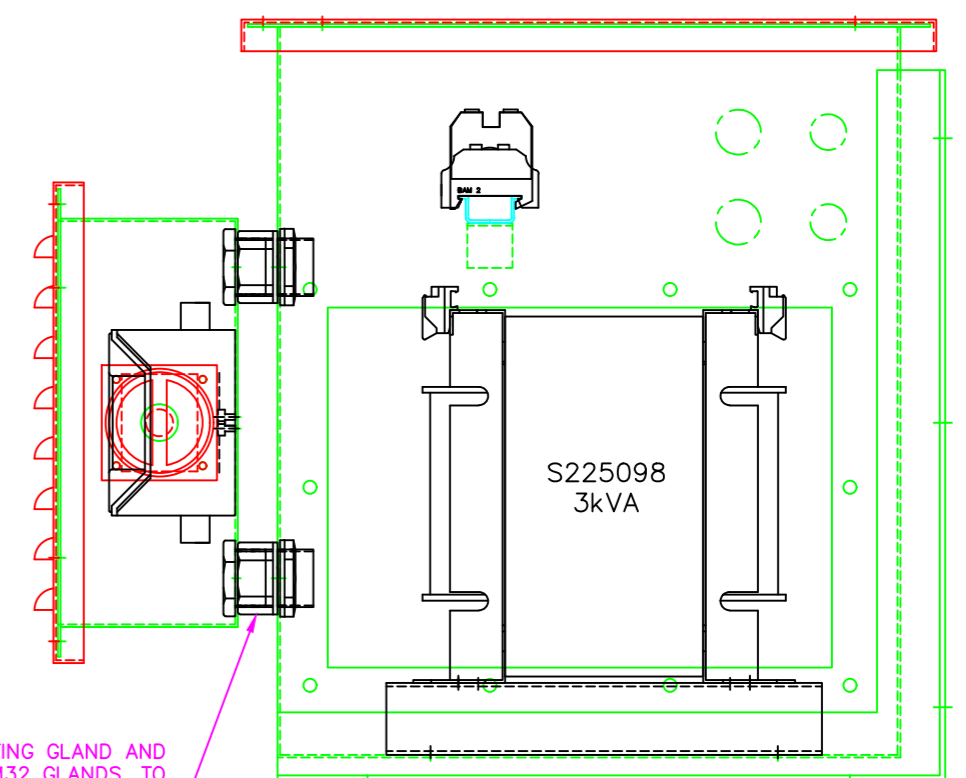

THIS DRAWING IS THE PROPERTY AND COPYRIGHT OF BLAKLEY ELECTRICS AND MUST NOT, WITHOUT THEIR WRITTEN CONSENT, BE PASSED ON, COPIED, OR USED FOR ANY OTHER PURPOSE. THIS COPY IS UNCONTROLLED UNLESS OTHERWISE MARKED.

REV: -															
EDR: -															
UNLESS OTHERWISE STATED:- ALL DIMENSIONS IN MM. EWM REFERS TO ENGINEERING & WORKSHOP MANUAL TOLERANCES TO EWM SECTION 3.1.3 FIXING STD TO EWM APPENDIX D. WIRING STD EWM SECTION 4. WELDING STANDARD TO QAI 061.										MATERIAL		BASED ON			
DO NOT SCALE THIS DRAWING. IF IN DOUBT, ASK										REF. S210411		COPY ISSUED 12 Sep 2022			
TITLE										ORIGINAL SCALE 1:4					
GENERAL ASSEMBLY FOR TH/1/3/415-110/CTE SELLAFIELD										DATE 20.04.22					
										DRN. B.W.		REVISION			
										CHKD.					
										APPD. BWA		SHEET 2 OF 2			

1 2 3 4 5 6 7 8 9 10 11 12

A2